

Part Number Guide

T-M-FF.FFFM-LC-FTFS-OT-ESR-TR-S

T (Type型号): D=5x7 SMD 4pads

DB=5x7 SMD 2pads

M (Mode of Operation振荡模式): F=Fundamental T=Third Overtone, etc

F (Frequency标称频率): Normal - 5 digitals of Frequency, e.g. 8.0000M, 12.000M

Special - All digitals of Frequency, e.g. 13.225625M

LC (Load Capacitance负载电容): 20=20pf 00=series, etc

FT (Frequency Tolerance调整频差): 30=±30 ppm, etc

FS (Frequency Stability温度频差): 50=±50 ppm, etc

OT (Operating Temperature工作温度): 1060=-10°C to +60°C 4085=-40°C to +85°C, etc

ESR (Equivalent Series Resistance等效阻抗)

TR (Tape and Reel编带)

S (Special Requirement特殊要求)

Electrical Specifications 电气参数

型号	Holder Type	5x7mm Ceramic Surface Mount
频率范围	Frequency Range	5.5000MHz to 150.00MHz
调整频差	Frequency Tolerance (ΔF) (at 25°C)	±10ppm to ±100ppm
温度频差	Frequency Stability	±10ppm to ±100ppm
工作温度范围	Operating Temperature Range	-10°C ~ +60°C to -40°C ~ +85°C
储存温度范围	Storage Temperature Range	-40°C ~ +85°C / -55°C ~ +125°C
老化	Aging (25°C)	±5ppm/year Maximum
静电容	Shunt Capacitance (C0)	7pF Maximum
激励功率	Drive Level	100μW Typical
绝缘阻抗	Insulation Resistance (Rs)	500 Megaohms Minimum at D.C100V
负载电容	Load Capacitance (CL)	Suggested by customer

Equivalent Series Resistance and Mode of Operation 等效阻抗和振荡模式

Frequency Range 频率范围	ESR (Ω) 等效阻抗	Mode 振荡模式
5.5000 - 8.0000MHz	100Max	Fundamental
8.0000 - 10.0000MHz	60Max	Fundamental
10.0000 - 14.0000MHz	50Max	Fundamental
14.0000 - 20.0000MHz	40Max	Fundamental
≥20.0000MHz	30Max	Fundamental
35.0000 - 150.00MHz	80Max	Third Overtone

Reflow Condition 回流焊条件

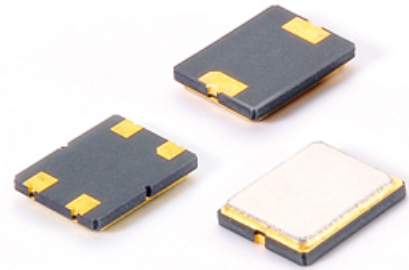
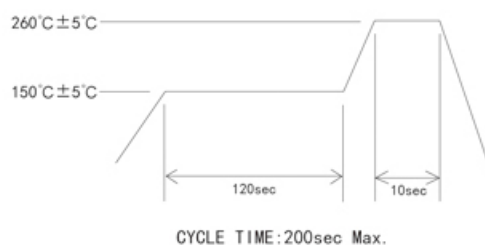

Pb Free **RoHS Compliant**
Directive 2002/95/EC

Mechanical Dimensions 外型尺寸

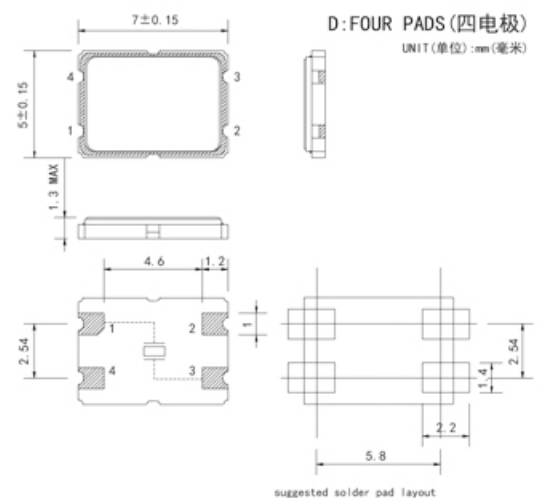
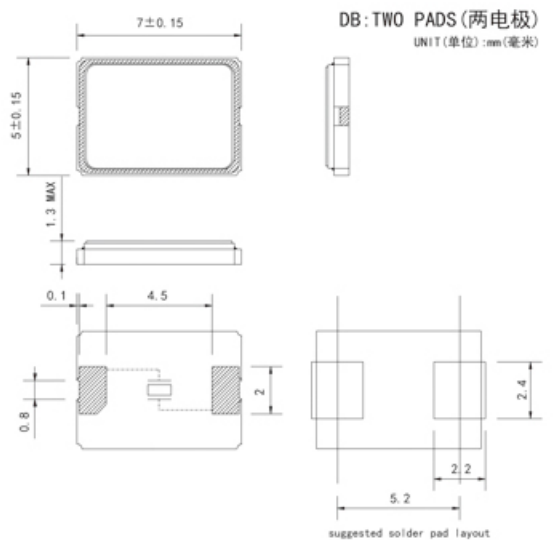

Note) #2, #4 is connected with a cover.
(Please connect with a GND or a power supply)